

138T Symmetrical Panel

Product Data

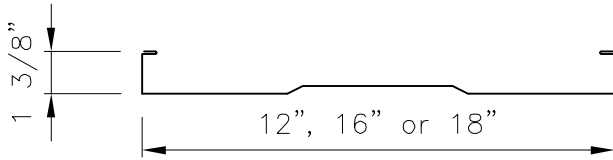

PLANK & PENCIL PROFILE (Standard)



PLANK PROFILE

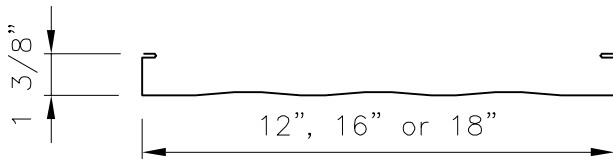

STRIATED PROFILE

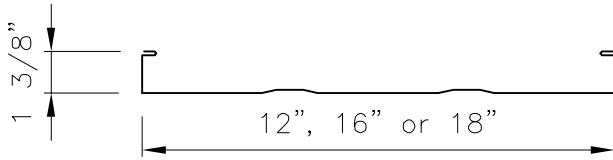

MINOR RIBS PROFILE

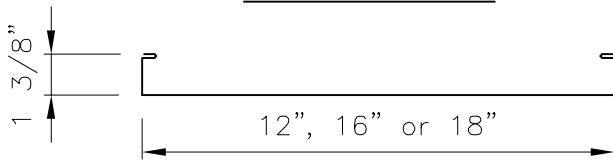

FLAT PROFILE

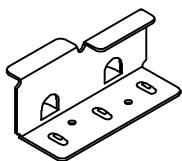

STANDARD CLIP

16 GA. Galvanized G90 - ASTM A635 (50 ksi)
16 GA. Stainless 304SS - ASTM A240 (50 ksi)

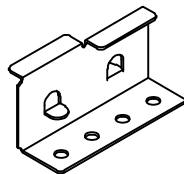

4" ASV CLIP

16 GA. Galvanized G90 - ASTM A635 (50 ksi)
16 GA. Stainless 304SS - ASTM A240 (50 ksi)

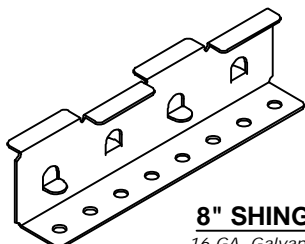

8" SHINGLE RECOVER CLIP

16 GA. Galvanized G90 - ASTM A635 (50 ksi)
16 GA. Stainless 304SS - ASTM A240 (50 ksi)

Applications

Symmetrical roof/wall panel used on slopes down to 1:12. Continuous length up to 80'. Convex curving only - 10ft minimum radius.

Substrates

Plywood, Metal Deck

Material

Standard - 24 GA. ASTM A792 (50 ksi)

Optional - 22 GA. ASTM A792 (50 ksi)

- .040 Aluminum ASTM B209 3003

- 20oz. & 16oz. Copper ASTM B307 cold-rolled sheet

H00 or H01 Temper **Special Order/Houston Plant Only**

Manufacturing

Roll formed in factory or at jobsite.

Finishes

Acrylic Coated Galvalume®

Fluoropolymer (Kynar 500® PVDF resin-based)

Pan Conditions

Plank & Pencil Rib, Plank, Striated, Minor Ribs and Flat

(Oil canning is inherent in all metal panels and is not cause for panel rejection. A signed oil canning acknowledgement will be required for all orders prior to production.)

Testing *

Uplift: UL 580, UL 1897, ASTM E1592

Air & Water Infiltration: ASTM E1680, ASTM E1646

Florida Product Approval: FL 22330 (Shingle Recover System)

Impact Resistance: UL Class 4, FM Class 1-SH

*Testing and Approvals are product specific. Please inquire for details. *

NOTE:

All data represented on this sheet may not be applicable to all widths and gauges. Please contact McElroy Metal for more information.

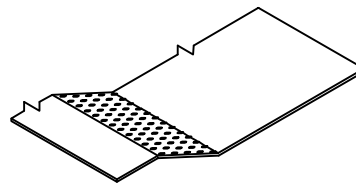

VENTED EAVE/RIDGE TRIM for 138T

0.063 Aluminum - ASTM B209 3003

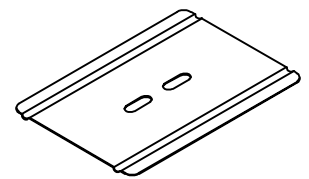

BEARING PLATE

24 GA. - ASTM A792 (50 ksi)

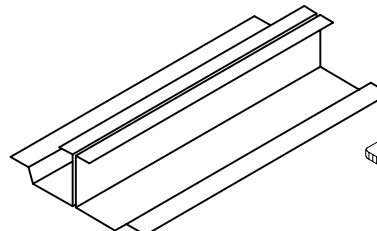

MULTI-SPAN CLIP

2-Piece

Standard: 24 GA. - ASTM A792 (50 ksi)

Optional: 22 GA. - ASTM A792 (50 ksi)

Typically sold in 10' lengths

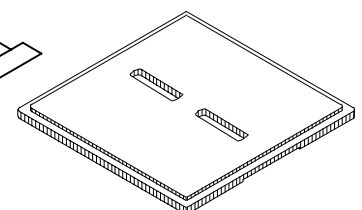

STACKABLE LEVELING SHIM

6" x 6" x 1/4" Thick

138T Symmetrical Panel (Continued)

Product Data

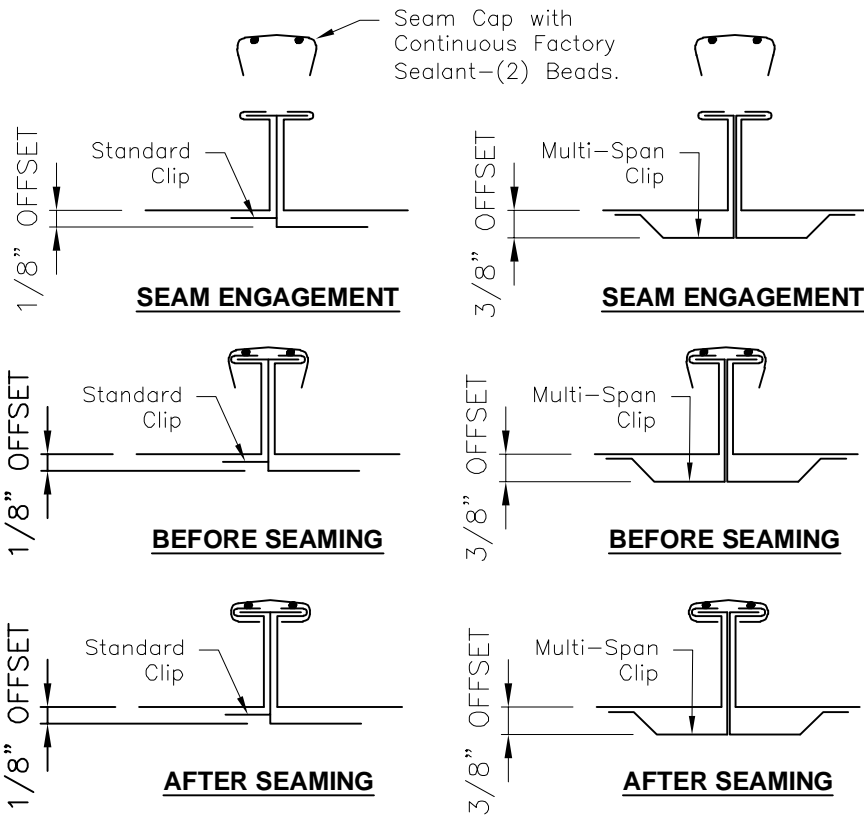

MECHANICAL SEAMER

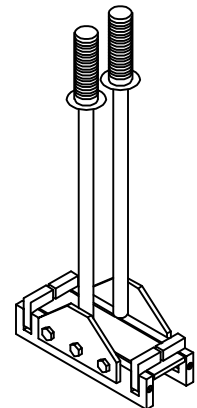

HAND SEAMER

NOTE:

All data represented on this sheet may not be applicable to all widths and gauges. Please contact McElroy Metal for more information.

