

SUBMITTAL DATA: SEZ-KD09NA4 & SUZ-KA09NA 9,000 BTU/H HORIZONTAL-DUCTED HEAT-PUMP SYSTEMS

Job Name:	Location:	Date:
Purchaser:	Engineer:	
Submitted to:	For <input type="checkbox"/> Reference <input type="checkbox"/> Approval <input type="checkbox"/> Construction	
System Designation:	Schedule No.:	

GENERAL FEATURES

- Horizontal-ducted indoor unit for concealed
- Ultra thin body: 7-7/8" high
- Built-in drain mechanism for condensate removal; lifts to 21-11/16"
- Air filter is included with indoor unit
- Quiet operation — as low as 23 dBA
- Indoor unit powered from outdoor unit using A-Control
- Automatic fan speed control
- Auto restart following a power outage
- Limited warranty: five years on parts/defects; seven years on compressors

OPTIONAL ACCESSORIES
Indoor Unit

- Filter Box with MERV 8 Filters (FBL1-1)
- Bottom Return Plate (BRP-1)

Outdoor Unit

- Drain Socket (MAC-860DS)
- Drain Pan Heater (MAC-640BH-U)
- Three-pole Disconnect Switch (TAZ-MS303)
- Air Outlet Guide (MAC-856SG)
- Mounting Base (DSD-400N)
- Mounting Pad (ULTRILITE1)
- Wall-mounting Brackets (CWMB1)

Controller Options

- Wireless Remote Controller Kit (MHK1) with Remote Controller (MRCH1), Wireless Receiver (MIFH1), and cable (MRC1)*
- Setback down to 50°F when used with MRCH1 Remote Controller
- Portable Central Controller (MCCH1; for use with Wireless Remote Controller Kit MHK1)*
- Outdoor Air Sensor (MOS1; for use with Remote Controller (MRCH1), Wireless Remote Controller Kit (MHK1) and Portable Central Controller (MCCH1)*

*See Submittal for information on each option.

- Wall-mounted Wired Remote Controller (PAR-21MAA)
- M-NET Control Adapter (MAC-399IF)
- Remote Temperature Sensor (M21-JKO-307)
- Hand-held Wireless Remote Controller (PAR-FL32MA; req. PAR-FA32MA-E)
- Wireless Signal Receiver Module PAR-FA32MA (for PAR-FL32MA-E)
- Lockdown Bracket for Handheld Controller (RCMKP1CB)

Cooling*

Rated Capacity 8,100 Btu/h
Capacity Range 3,800 - 10,900 Btu/h
SEER 15.0
Total Input 670 W

Heating at 47°F*

Rated Capacity 10,900 Btu/h
Capacity Range 4,800 - 14,100 Btu/h
HSPF 10.0
Total Input 1,020 W

Heating at 17°F*

Rated Capacity 6,700 Btu/h
Rated Total Input 810 W
Maximum Capacity 6,700 Btu/h
Maximum Total Input 1,000 W

*Rating Conditions (Cooling)-Indoor: 80°F(27°C)DB, 67°F(19°C)WB; Outdoor: 95°F(35°C)DB, 75°F(24°C)WB.
(Heating at 47°F) - Indoor: 70°F(21°C)DB, 60°F(16°C)WB; Outdoor: 47°F(8°C)DB, 43°F(6°C)WB.
(Heating at 17°F) - Indoor: 70°F(21°C)DB, 60°F(16°C)WB; Outdoor: 17°F(-8°C)DB, 15°F(-9°C)WB.

Electrical Requirements

Power Supply 208 / 230V, 1-Phase, 60 Hz
Recommended Fuse/Breaker Size 15 A

OPERATING CONDITIONS

		Indoor Intake Air Temp.	Outdoor Intake Air Temp.
Cooling	Maximum	90°F (32°C) DB, 73°F (23°C) WB	115°F (46°C) DB
	Minimum	67°F (19°C) DB, 57°F (14°C) WB	14°F (-10°C) DB
Heating	Maximum	80°F (27°C) DB, 67°F (19°C) WB	75°F (24°C) DB, 65°F (18°C) WB
	Minimum	70°F (21°C) DB, 60°F (16°C) WB	-4°F (-20°C) DB, -5°F (-21°C) WB

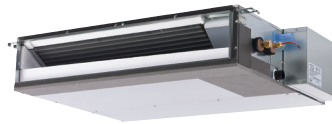

Indoor Unit: SEZ-KD09NA4



Outdoor Unit: SUZ-KA09NA

Voltage

Indoor - Outdoor S1-S2 AC 208 / 230V
Indoor - Outdoor S2-S3 DC 12-24V

Indoor Unit

MCA 1 A
Fan Type x Quantity Sirocco Fan x 2
Fan Motor Type Direct-driven DC Brushless Motor
Fan Motor Output 96 W
Fan Motor 0.51 F.L.A.
Airflow (Lo - Med - Hi) 194 - 247 - 317 Dry CFM
174 - 222 - 285 Wet CFM
Air Filter Polypropylene Honeycomb
External Static Pressure 0.02 - 0.06 - 0.14 - 0.20"WG
Sound Pressure Level (Lo - Med - Hi) 23 - 26 - 30 dB(A)

DIMENSIONS	UNIT INCHES / MM
W	31-1/8 / 790
D	27-9/16 / 700
H	7-7/8 / 200

Weight 42 lbs. / 19 kg
External Finish Galvanized-steel Sheets
Field Drainpipe Size O.D. 1-1/4" / 32 mm

Outdoor Unit

Compressor DC Inverter-driven
MCA 12 A
MOCP 15 A
Fan Motor 0.50 F.L.A.
Sound Pressure Level
Cooling 46 dB(A)
Heating 50 dB(A)

DIMENSIONS	INCHES / MM
W	31-1/2 / 800
D	11-1/4 / 285
H	21-5/8 / 550

Weight 66 lbs. / 30 kg
External Finish Munsell No. 3Y 7.8 / 1.1
Refrigerant Type R410A
Refrigerant Pipe Size O.D.
Gas Side 3/8" / 9.52 mm
Liquid Side 1/4" / 6.35 mm
Max. Refrigerant Pipe Length 65' / 19 m
Max. Refrigerant Pipe Height Difference 40' / 12 m
Connection Method Flared



SEZ-KD09NA4 INDOOR FAN PERFORMANCE AND CORRECTED AIR FLOW CHARTS

SEZ-KD09NA4

(External static pressure 0.02[in.WG](5Pa) 208/230V 60Hz)

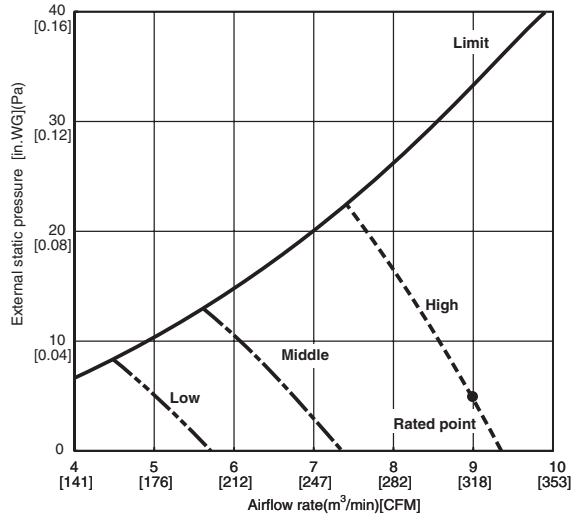

SEZ-KD09NA4

(External static pressure 0.06[in.WG](15Pa) 208/230V 60Hz)

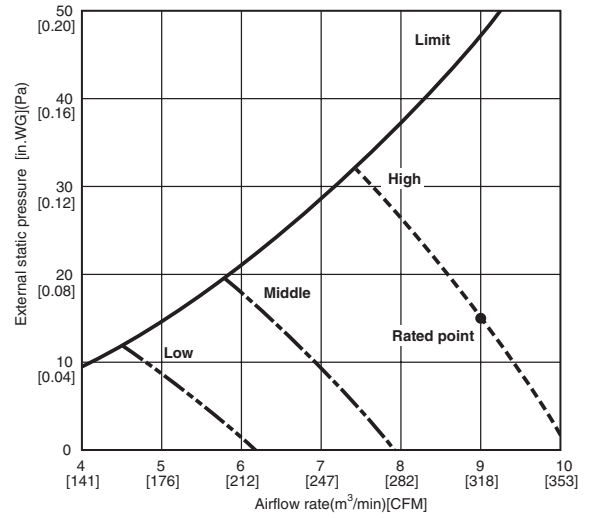

SEZ-KD09NA4

(External static pressure 0.14[in.WG](35Pa) 208/230V 60Hz)

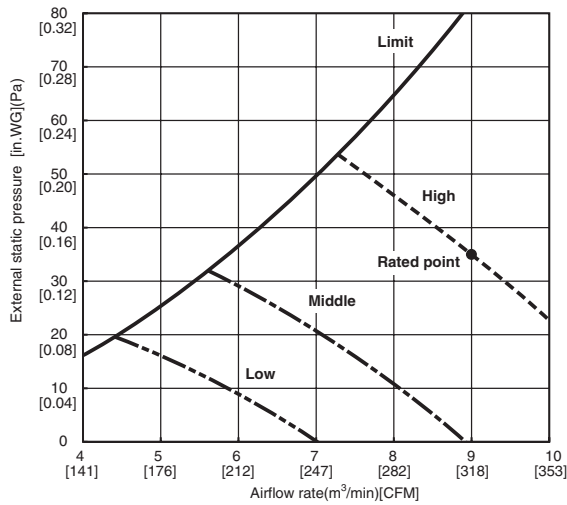

SEZ-KD09NA4

(External static pressure 0.20[in.WG](50Pa) 208/230V 60Hz)

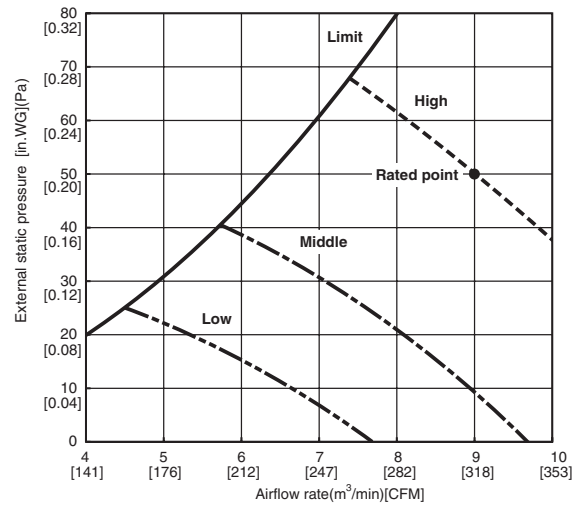

DIMENSIONS: SEZ-KD09NA4

Unit : mm(in.)

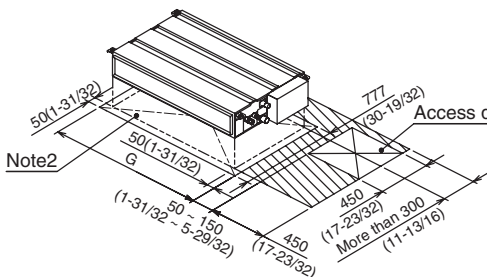
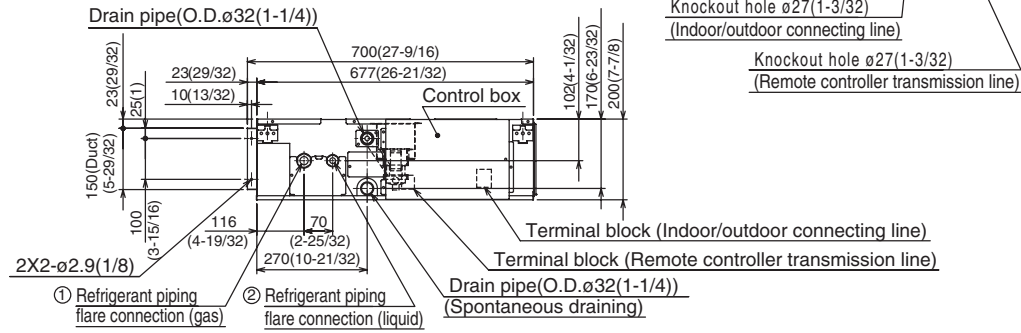
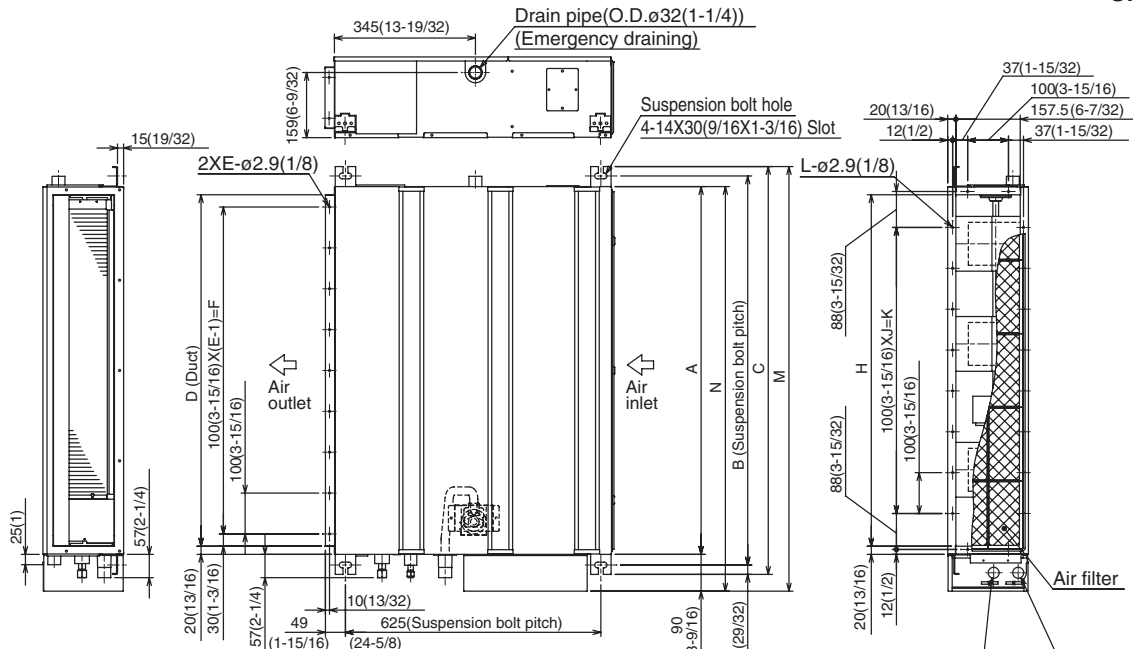

Required space for service and maintenance

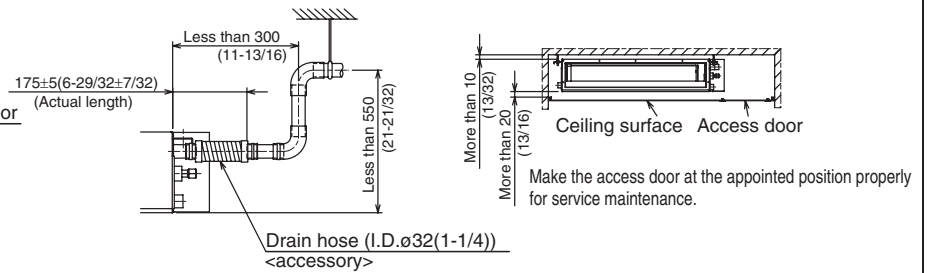

mm(in.)

Model	A	B	C	D	E	F	G	H	J	K	L	M	N	① Gas pipe	② Liquid pipe
SEZ-KD09NA4	700 (27-9/16)	752 (29-5/8)	798 (31-7/16)	660 (26)	7	600 (23-5/8)	800 (31-1/2)	660 (26)	5	500 (19-11/16)	16	839 (33-1/16)	790 (31-1/8)	$\phi 9.52(3/8)$	$\phi 6.35(1/4)$
SEZ-KD12NA4	900 (35-7/16)	952 (37-1/2)	998 (39-5/16)	860 (33-7/8)	9	800 (31-1/2)	1000 (39-3/8)	860 (33-7/8)	7	700 (27-9/16)	20	1039 (40-29/32)	990 (39)		
SEZ-KD15NA4	1100 (43-5/16)	1152 (45-3/8)	1198 (47-3/16)	1060 (41-3/4)	11	1000 (39-3/8)	1200 (47-1/4)	1060 (41-3/4)	9	900 (35-7/16)	24	1239 (48-25/32)	1190 (46-7/8)		
SEZ-KD18NA4															

- Note1. Use M10 screw for the suspension bolt (field supply).
 Note2. Keep the service space for the maintenance at the bottom.
 Note3. This chart indicates for SEZ-KD15NA4 model, which has 3 fans.
 SEZ-KD09, 12NA4 models have 2 fans.
 SEZ-KD18NA4 models have 4 fans.
 Note4. In case an inlet duct is used, remove the air filter (supply with the unit), then install the filter (field supply) at suction side.

DIMENSIONS: SUZ-KA09NA

Unit: inch

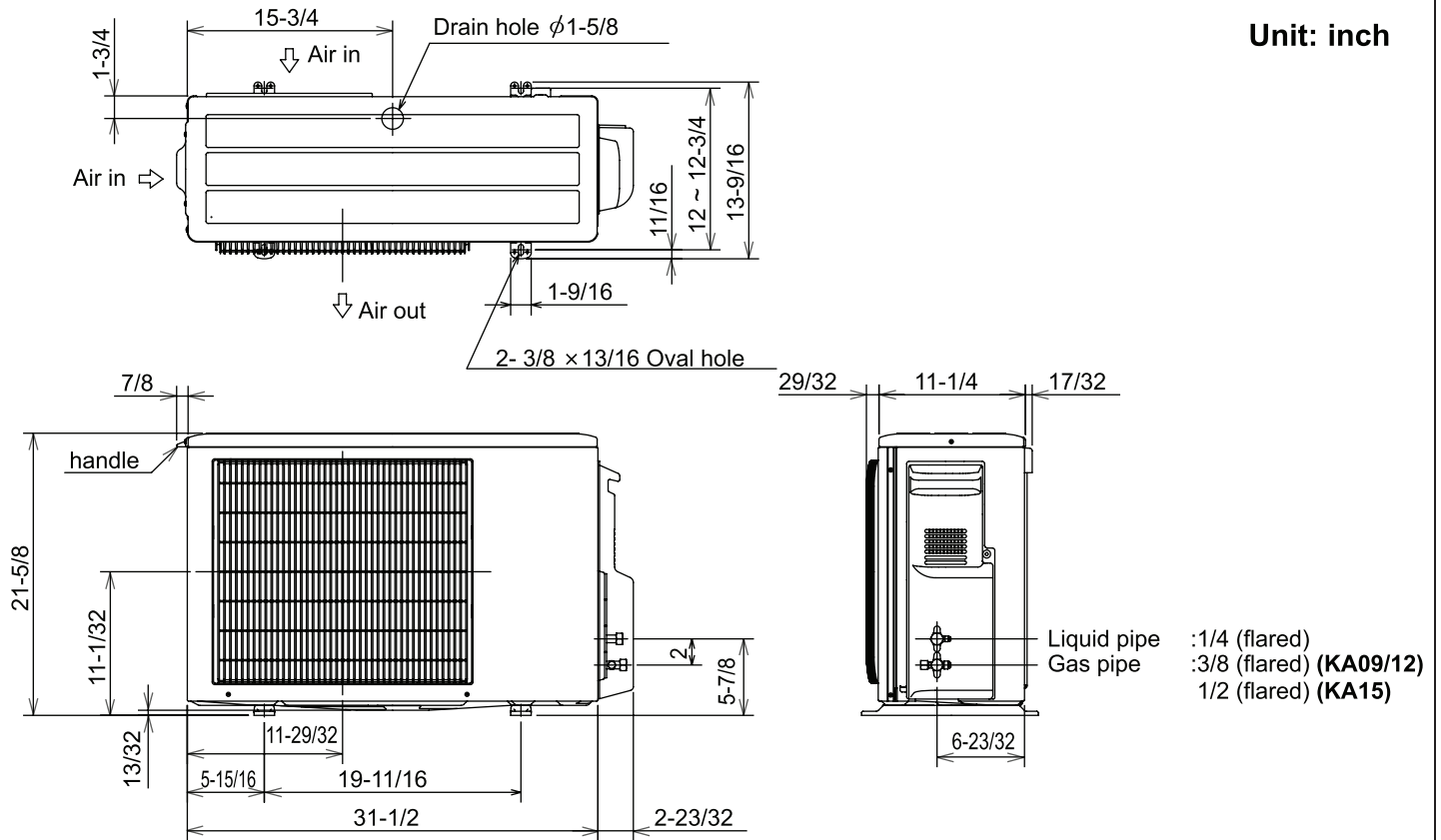

REQUIRED SPACE

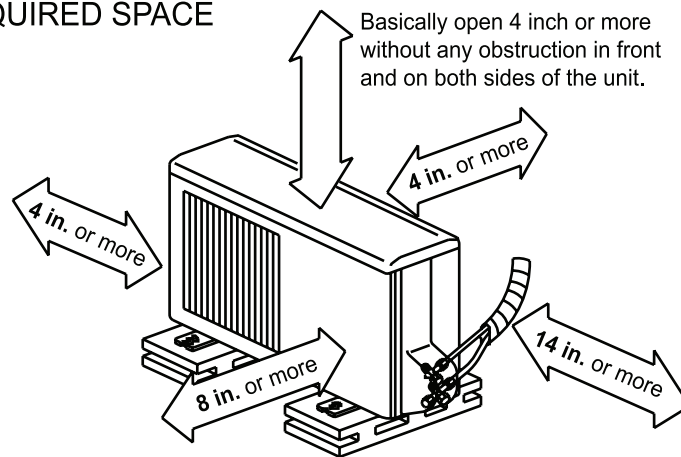

Open two sides of left, right, or rear side.



Intertek

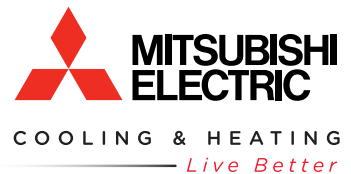

3400 Lawrenceville Suwanee Rd
 Suwanee, GA 30024
 Tele: 678-376-2900 • Fax: 800-889-9904
 Toll Free: 800-433-4822 (#3)
 www.mehvac.com
Specifications are subject to change without notice.